

CENTURY 21.
Approved Vendor

HOME COLONIAL SIGNPOST

DIVISION OF ROBWOOD INC



WE SHIP ACROSS CANADA



CENTURY 21.

Approved Vendor

OUR NEW ILLUSTRATED CATALOGUE 2026 rev 1

T. 450 477-2828 |

F. 450 477-6819 |

HcsSigns@icloud.com



Applicable to all of Canada except Ontario

Each CENTURY 21[®] Office is Independently Owned and Operated. © Registered trademark of Century 21 Real Estate LLC, used under license. TM Trademark of Century 21 Real Estate LLC, used under license.

Applicable to Ontario only

Independently Owned and Operated. © Registered trademark of Century 21 Real Estate LLC, used under license. TM Trademark of Century 21 Real Estate LLC, used under license.

HOME COLONIAL SIGNPOST

DIVISION OF ROBWOOD INC

How to assemble and install	4
Imagemaker sign post.....	5
Residential Yard Signs 60" Post System.....	6-7-8-9
Residential 36" Yard Signs.....	10-11-12
Name Riders Personalize your Rider with a photo.....	13
Complete Steel Frame Kit Special.....	14
Extra large Commercial Signs.....	15
Commercial Signs.....	16-17-18
Fine Homes and Estates.....	19
Sign Post kit.....	20-21-22
Sign Riders.....	23
Sign Stickers.....	24
Open House Signs.....	25-26
Sign Accessories.....	27-28
Directional Sign.....	29
Quick-up Directional Signs.....	30
Sign Accessories.....	31-32
Personal Promotional Products.....	33-37
Order Form.....	38

The Igemaker Sign Post

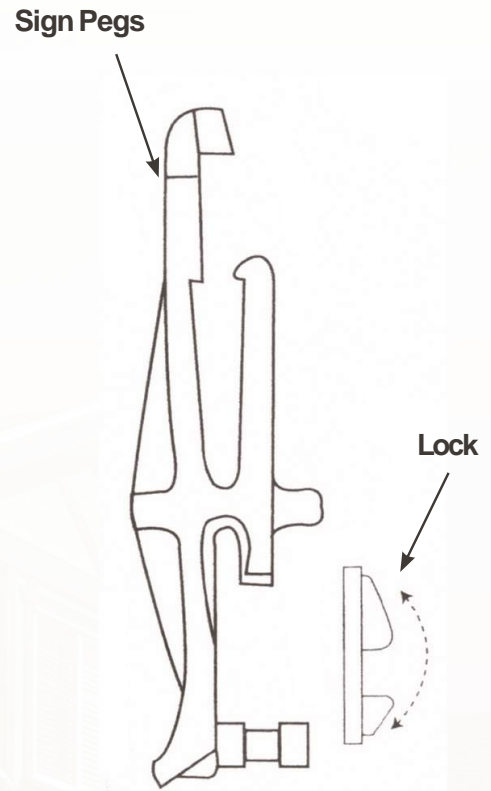
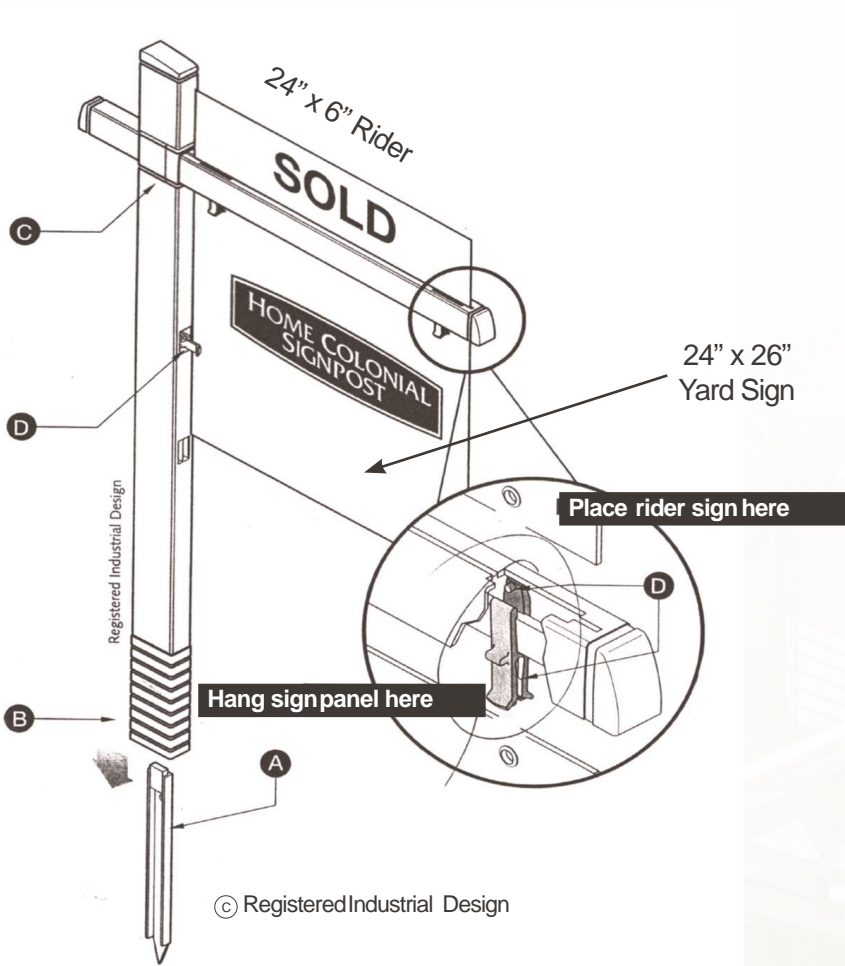

(For hanging main sign panel beneath cross-arm, and, for attaching side of main sign panel to upright post to prevent swinging)

QUICK'N EASY

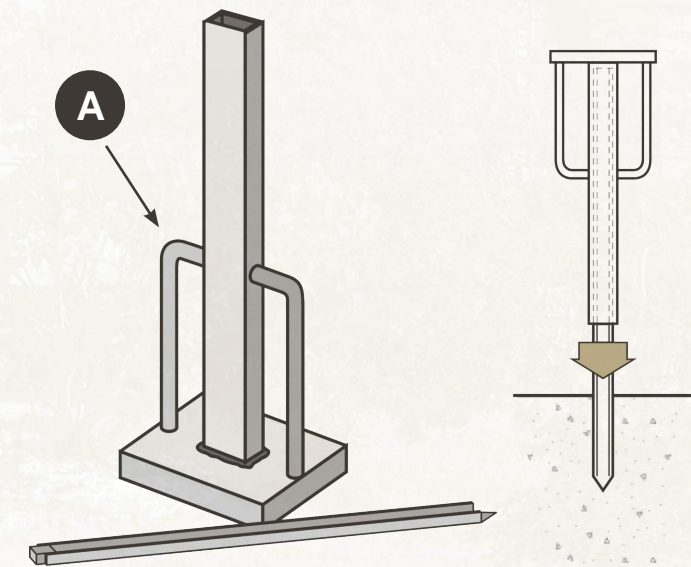

- A** Pound stake into soil using a stake hammer (stop at the yellow line):
- B** Slide upright portion of post onto top of stake;
- C** Slide crossarm portion into upright until snap;
- D** Insert sign pegs in post and hang sign panel;
- E** Slide messenger rider sign into slot of crossarm;

« Snap Assembly » Sign Post System

ITEM#2005P

Main Post 60", CrossArm 36"



White Post



New Gold Post



Black Post

Includes sign post assembly & ground stake.

- QTY: 3 Per Box
- Model A = \$ 100.30 each post
 - Model B = \$ 112.25 each post
 - Model C = \$ 106.95 each post

Available in boxes of 3 only

Quick'n easy to install:

- A) Pound stake into ground with stakehammer
Item #7095, page 30
- B) Slide upright portion of post onto top of stake;
- C) Slide crossarm portion into upright until it snaps;
- D) Insert sign pegs in post until they clip, hang sign panel, and then slide rider sign into slot of crossarm.

2 PRODUCT WARRANTY YEARS!*

*Your Imagemaker Signpost warranty covers all defects in materials and workmanship.

The following are not covered by the warranty:

- 1- Units on which the manufacture date has been defaced, modified or removed.
- 2- Damage or deterioration resulting from:
 - A- Installation or removal of the signpost
 - B- Accident, misuse, abuse, neglect, unauthorized product modification.
 - C- Installation of parts or accessories that do not conform to the quality or specification of the original sign post or accessories

Please Photocopy
AND ATTACH TO ORDER FORM

Yard Signs 60" Sign Post System

ITEM#6005

Model A



24" x 18" - Corrugated Plastic Sign Panel - 4 mm

- Choose from two color schemes!
- 24" x 18" sign panel
- Printed 2 sides
- Imprinted with DBA, phone number and website
- Standard 5 grommets hole pattern

Yard sign printing specifications:

Sign Model A B C
5 grommets or no grommets

To fit Steel Frames

- 6 = \$ 26.60 each
- 12 = \$ 25.20 each
- 24 = \$ 23.80 each

Model B



Same Sign Printed 1 Side Only

Sign Model A B C
 6 = \$ 23.95 each
 12 = \$ 22.70 each
 24 = \$ 21.55 each

Model C



A) Company Name: **CENTURY 21**

DBA _____

B) Agent Name: _____

C) Title: _____

D) Agent Website or Email Agent Name: _____

E) Agent Phone Number: _____

*Note: For quality purpose, agent photos should be taken at the highest possible resolution, but no less than 5.5" x 5.5" at 300dpi (dots per inch). Color photos can be used.

**Please Photocopy
AND ATTACH TO ORDER FORM**

Yard Signs 60" Sign Post System

ITEM#6010

24" x 26" Yard Sign With Associate Identifier

Model A



DESCRIPTION:

- Printed 2 sides
- 4 mm coroplast office identification sign Imprinted with DBA, Website and phone number
- White coroplast can be translucent in very bright areas

Choose from three color schemes!



Model B



- 6 = \$ 35.00 each
- 12 = \$ 33.60 each
- 24 = \$ 32.20 each

Yard sign printing specifications:

3 grommets or no grommets

A) Company Name: **CENTURY 21**

DBA _____

B) Agent Name: _____

C) Title: _____

D) Agent Website or Email: _____

E) Agent Phone Number: _____

Model C



Model D



Model E

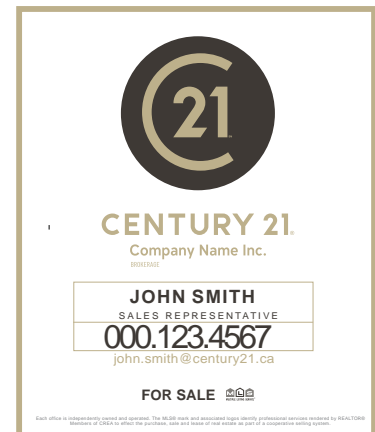

Model D & E also available in kit form.

**Please Photocopy
AND ATTACH TO ORDER FORM**

Yard Signs 60" Sign Post System

ITEM#6015

Model A

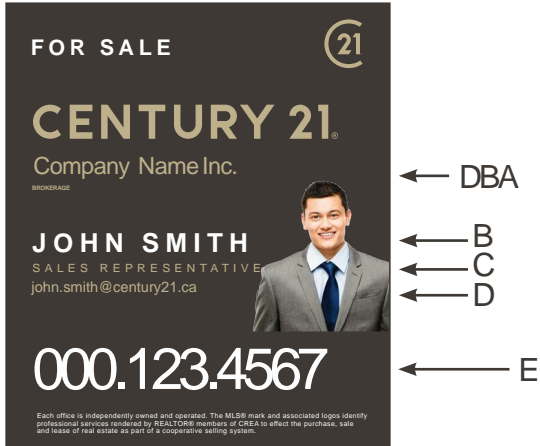

Model B

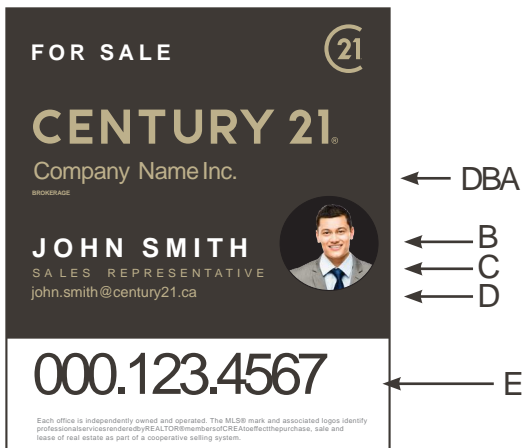

Model C

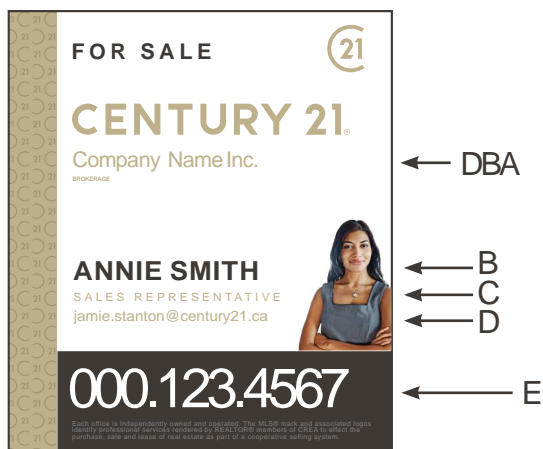

24" x 26" - Yard Sign With Associate Identifier & Agent Photo

DESCRIPTION:

Yard sign printing specifications:

- 4 mm coroplast office identification sign
- Printed 2 sides

Choose from two photos schemes!



- 3 grommets (two (2) on top and one (1) on left side of sign)



3 grommets or no grommets

*Note: For quality purpose, agent photos should be taken at the highest possible resolution, but no less than 5.5" x 5.5" at 300 dpi (dots per inch). Color photos can be used.

Photo on file Sending photo by email

Forward photo in 300 DPI by Email to: HcsSigns@icloud.com

Company Name: **CENTURY 21**

DBA _____

B) Agent Name: _____

C) Title: _____

D) Agent Website or Email Agent Name: _____

E) Agent Phone Number: _____

Model D



Yard Signs 60" Sign Post System

ITEM#6020

Model A

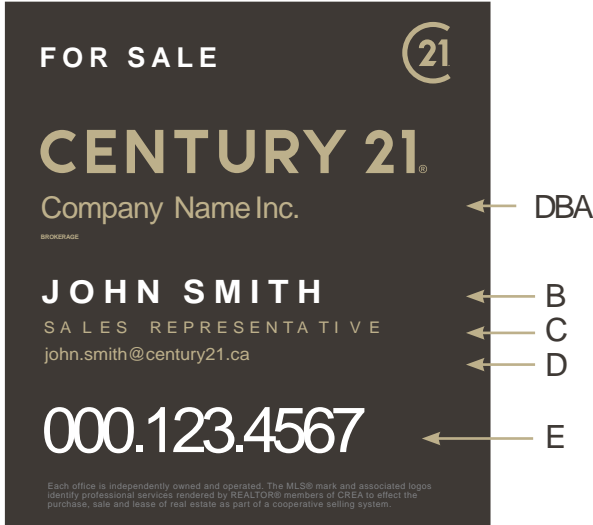

24"x 26" - Yard Sign With Associate Identifier

DESCRIPTION:

- **Printed 1 side only**
- 4 mm coroplast office identification sign Imprinted with DBA, Website and phone number
- Choose from two color schemes!**



Model A B

- 6 = \$ 31.50 each
- 12 = \$ 30.25 each
- 24 = \$ 29.00 each

A) Company Name: **CENTURY 21**
DBA _____

B) Agent Name: _____

C) Title: _____

D) Agent Website or Email Agent Name: _____

E) Agent Phone Number: _____

ITEM#6025

Model B

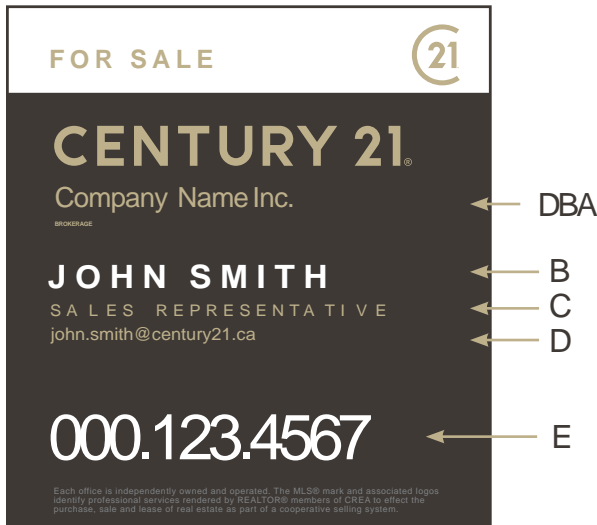

24"x 26" - Yard Sign With Associate Identifier

DESCRIPTION: DOUBLE

- 2 coroplast signs back to back glued 4 corners
- 4 mm coroplast office identification sign Imprinted with DBA, Website and phone number
- Choose from two color schemes!**



Model A B

- 6 = \$ 60.50 each
- 12 = \$ 58.00 each
- 24 = \$ 55.85 each

A) Company Name: **CENTURY 21**
DBA _____

B) Agent Name: _____

C) Title: _____

D) Agent Website or Email Agent Name: _____

E) Agent Phone Number: _____

**Please Photocopy
AND ATTACH TO ORDER FORM**

36" Yard Signs

ITEM#6030

Model A



36" x 32" Yard Sign With Associate Identifier

DESCRIPTION:

- Printed 2 sides

Choose from two color schemes!

Imprinted with DBA, Website and phone number

- 4 mm coroplast office & agent identification sign
- 4 grommets (2 on top and 2 on left side)



Model A B

3 = \$ 63.00 each

6 = \$ 60.20 each

9 = \$ 57.40 each

12 = \$ 54.60 each

Model B



A) Company Name: **CENTURY 21**

DBA _____

B) Agent Name: _____

C) Title: _____

D) Agent Website or Email: _____

E) Agent Phone Number: _____

* The CENTURY 21 Policy and Procedures Manual requires that brokers use the CENTURY 21 Colonial Post Sign made to Franchise Identification System Specifications unless prohibited from doing so by the client or by law or local ordinance. Yard signs depicted in other formats are offered for your convenience and should only be used when it is not possible to use the Colonial Post Yard Sign.

**Please Photocopy
AND ATTACH TO ORDER FORM**

36" Yard Signs

ITEM#6040

Model A



Model B



36" x 24" - Yard Sign

DESCRIPTION:

- **Printed 2 sides**
 - Imprinted with DBA, Website and phone number
- Choose from two color schemes!**
- White coroplast can be translucent in very bright areas



Sign Model A B

- 4 mm coroplast office identification sign
- 5 grommets (two(2) on top, one (1) left and two (2) on bottom)

5 = \$ 54.60 each

10 = \$ 53.20 each

15 = \$ 51.80 each

20 = \$ 50.40 each

Yard sign printing specifications:

5 grommets or no grommets

A) Company Name: **CENTURY 21**

DBA _____

B) Office Phone Number: _____

Please Photocopy
AND ATTACH TO ORDER FORM

36" Yard Signs

ITEM#6045

Model A

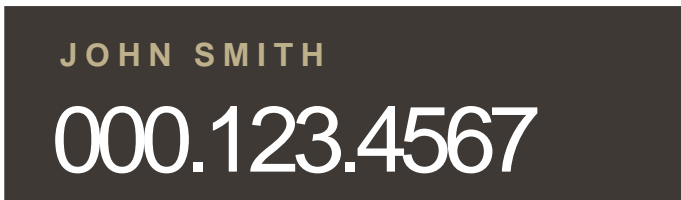

36" x 8" Name Rider

Description:

- Printed 2 sides
- 4 mm coroplast agent identification sign
- 2 grommets (on top or bottom)

Sign Model

Model A

6 = \$ 23.10 each

12 = \$ 21.70 each

24 = \$ 20.30 each

2 grommets Top or Bottom

A) Agent Name: _____

C) Agent Phone Number: _____

Model B



Model C



Model D



With photo 6"x6"

Model B C D

6 = \$ 24.05 each

12 = \$ 22.65 each

24 = \$ 21.25 each

2 grommets Top or Bottom

A) Agent Name: _____

C) Agent Phone Number: _____

ITEM#6085

Personalize Your Rider With a Photo

Model A

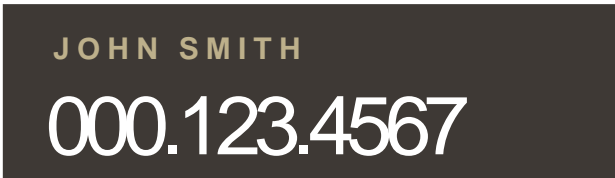

Model B



Model C



Model D



*Note: For quality purpose, agent photos should be taken at the highest possible resolution, but no less than 5.5" x 5.5" at 300 dpi (dots per inch). Color photos can be used.

Please E-mail photo to: HcsSigns@icloud.com

Please Photocopy
AND ATTACH TO ORDER FORM

24" x 6 - Agent Name Riders

Description:

- Printed 2 sides
- 4 mm coroplast agent identification sign

Model A

- 6 = \$ 13.30 each
- 12 = \$ 12.60 each
- 24 = \$ 11.90 each

2 grommets:

- Top or Bottom
- Center print for steel frames

24" x 8 - Agent Name Riders

Description:

- Printed 2 sides
- 4 mm coroplast agent identification sign with photo 5.5"x5.5"

Model B C D

- 6 = \$ 14.75 each
- 12 = \$ 14.05 each
- 24 = \$ 13.35 each

2 grommets:

- Top or Bottom

Sign Printing specifications:

A) Agent Name: _____

C) Agent Phone Number: _____

- Photo on file
- Sending photo by email

Complete Steel Frame Kit

ITEM #6075

SPECIAL

- (ITEM 6075)** A) 8 STEEL FRAMES (2 boxes)
- (ITEM 6005)** B) 8 YARD SIGNS
- (ITEM 6085)** C) 8 NAME RIDERS
- (ITEM 6090)** D) 4 "NEW PRICE"
- (ITEM 6090)** E) 4 "OPEN SUNDAY 2 TO 4"
- (ITEM 6090)** F) 4 "SOLD"

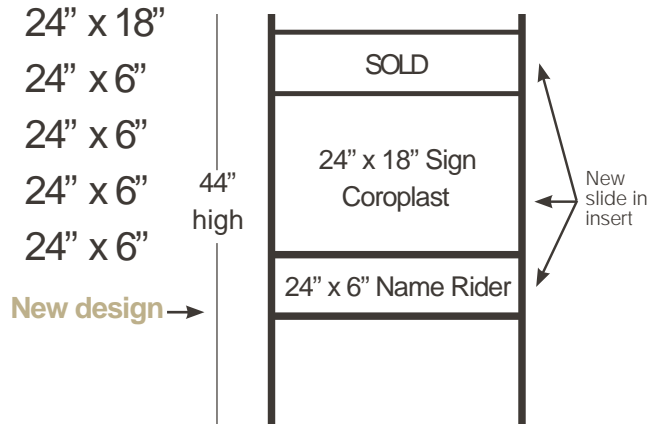

Choose from two color schemes!

Model A



Model B



Model C



Model A B C

A) Company Name: **CENTURY 21**

DBA _____

B) Office Phone number: _____

NAME RIDER

C) Agent Name: _____

D) Title: _____

E) Agent Phone Number: _____

Frame Item #7080 / see page 31

A value of \$ 950.00
for only **\$ 890.00**

* The CENTURY21 Policy and Procedures Manual requires that brokers use the CENTURY 21 Colonial Post Sign made to Franchise Identification System Specifications unless prohibited from doing so by the client or by law or local ordinance. Yard signs depicted in other formats are offered for your convenience and should only be used when it is not possible to use the Colonial Post Yard Sign.

Please Photocopy
AND ATTACH TO ORDER FORM

Commercial Signs

ITEM#6070

Model A



60” x 48” Extra Large Yard Sign

LARGE, ONE SIDED COROPLAST SIGN IDEAL FOR INDUSTRIAL, COMMERCIAL BUILDINGS, OPEN LOTS, ACREAGE.

Ready to install on buildings, etc. Coroplast signs are inexpensive to ship and easy to install.

Signs should be supported with wooden frame (1” x 3” furring).

DESCRIPTION:

- Printed one side
- 6 mm coroplast office identification sign.

Model A B

- 1 = \$ 196.00 each
- 2 = \$ 189.20 each
- 6 = \$ 175.00 each

Model B



YARD SIGN PRINTING SPECIFICATIONS:

- A) Company Name: **CENTURY 21**
- DBA _____
- B) Website: _____
- C) Office Phone Number: _____
- D) Agent name: _____
- E) Title: _____
- F) Agent Phone Number: _____
- G) Agent Website or Email: _____

Your Sign Message: _____

**Please Photocopy
AND ATTACH TO ORDER FORM**

Yard Signs 60" Sign Post System

ITEM #6060

Model A



24" x 26" - Commercial Yard Sign With Associate Identifier

DESCRIPTION:

- Printed 2 sides
- 4 mm coroplast office identification sign
- Imprinted with DBA and phone number

Model A B

3 = \$ 43.75 each

6 = \$ 35.00 each

12 = \$ 33.60 each

3 grommets or no grommets

Model B



Yard Sign Printing Specifications:

A) Company Name: **CENTURY 21**

DBA _____

B) Agent Name: _____

C) Agent Phone Number: _____

ITEM #6060R

Model A



24" x 8 - Message Riders

Description:

Model A

2 grommets: Top or Bottom

3 = \$ 17.85 each

6 = \$ 14.25 each

12 = \$ 13.55 each

Your Sign Message: _____

Commercial Signs

ITEM #6065

Model A



← DBA

← B

← C

48" x 48" - Large Yard Sign

LARGE, PRINTED ON ONE SIDE COROPLAST SIGN IDEAL FOR INDUSTRIAL, COMMERCIAL BUILDINGS, OPEN LOTS AND ACREAGE.

Ready to install on buildings, etc. Coroplast signs are inexpensive to ship and easy to install. Signs should be supported with wooden frame (1" x 3" furring).

DESCRIPTION:

- Printed 1 side only
- 6 mm coroplast office identification sign

48" x 48" - with upper message

Model B



← DBA

← B

← C

Model A B

- 1 = \$ 182.00 each
- 2 = \$ 175.00 each
- 6 = \$ 168.00 each

Your Sign Message: _____

A) Company Name: **CENTURY 21**

DBA _____

B) Agent Name: _____

C) Agent Phone Number: _____

Please Photocopy
AND ATTACH TO ORDER FORM

Commercial Signs

ITEM#6072

Model A



Model B



60" x 48" Extra Large Yard Sign

LARGE, ONE SIDED COROPLAST SIGN IDEAL FOR INDUSTRIAL, COMMERCIAL BUILDINGS, OPEN LOTS, ACREAGE.

Ready to install on buildings, etc. Coroplast signs are inexpensive to ship and easy to install.

Signs should be supported with wooden frame (1" x 3" furring).

DESCRIPTION:

- Printed one sided
- 6 mm coroplast office identification sign.

Model A B

- 1 = \$ 196.00 each
- 2 = \$ 189.00 each
- 6 = \$ 175.00 each

YARD SIGN PRINTING SPECIFICATIONS:

- A) CompanyName: **CENTURY 21**
- DBA _____
- D) Agent name: _____
- F) Agent Phone Number: _____
- G) Agent Website or Email: _____

Your Sign Message: _____

Please Photocopy
AND ATTACH TO ORDER FORM

**Main Post 60", CrossArm 36"
24" x 32" Fine Home & Estates Yard Sign**

ITEM #6050

Model A



DESCRIPTION:

- 4 mm coroplast office identification sign.
- Imprinted with DBA, Website and phone number

Model A

- | | |
|--|--------------------------------------|
| <input type="checkbox"/> 3 = \$43.75 each | <input type="checkbox"/> 4 grommets |
| <input type="checkbox"/> 6 = \$37.80 each | <input type="checkbox"/> No grommets |
| <input type="checkbox"/> 12 = \$36.40 each | |
| <input type="checkbox"/> 24 = \$35.00 each | |

Riders 24" x 8 - Die-Cut

- 3 = \$24.90 each



ITEM #6055

SPECIAL

COMPLETE FINE HOMES & ESTATES SIGN POST KIT

DESCRIPTION:

- A) 3 IMAGE MAKER 60" BLACK SIGN POSTS (1 box) complete with ground stakes & 3 extra pegs
- B) 3 Yard signs (24" x 32")
- C) 3 Personalized riders with photo



Forward photo in 300 DPI by e-mail to : HcsSigns@icloud.com

- Photo on file Sending photo by email

Logos  

Company Name: **CENTURY 21**

- A) DBA _____
- B) Agent name: _____
- C) Agent Phone Number: _____
- D) Agent Website or Email: _____



**Please Photocopy
AND ATTACH TO ORDER FORM**

60" Sign post system

CENTURY21

ITEM#9000A

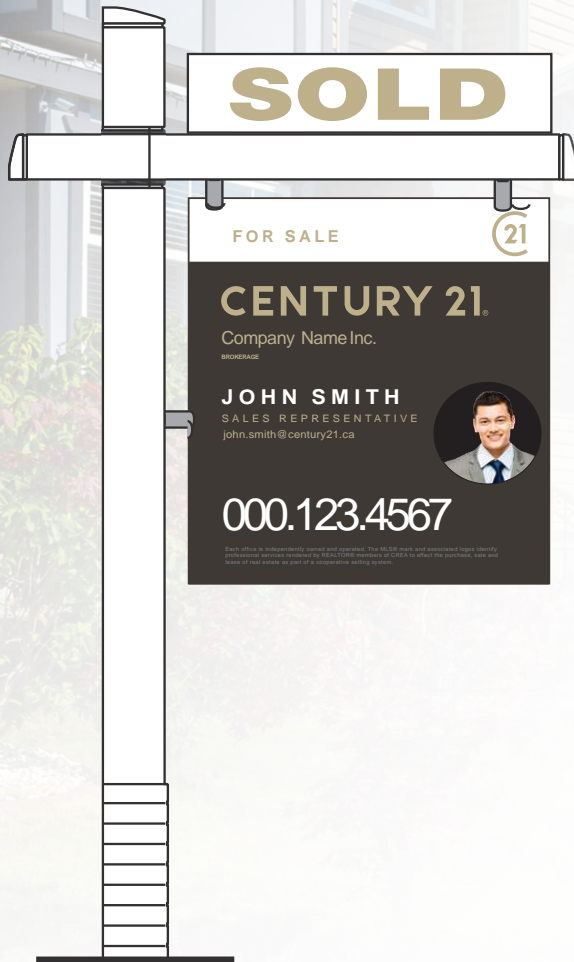

SPECIAL

COMPLETE SIGN POST KIT WITH PICTURE

Model A

DESCRIPTION:

- A) 6 IMAGE MAKER 60" SIGN POSTS (2 boxes)
complete with ground stakes & pegs
- B) 6 Yard signs (24" x 26") with associated identifier
- C) 12 Message riders (24" x 6")
 - 3 "NEW PRICE"
 - 3 "Open Sunday 2 to 4"
 - 3 "JUST LISTED"
 - 3 "SOLD"

Photo on file* Sending photo by email*

Logos  

CompanyName: **CENTURY 21**

- A) DBA _____
- B) Agent name: _____
- C) Title: _____
- D) Agent Phone Number: _____
- E) Agent Email: _____
- F) Agent Website: _____

* Note: For quality purpose, agent photos should be taken at the highest possible resolution, but no less than 5.5" x 5.5" at 300 dpi (dots per inch). Color photos can be used.

Please E-mail photo to: HcsSigns@icloud.com

A value of \$ 975.00
for only **\$ 905.00**

* The CENTURY 21 Policy and Procedures Manual requires that brokers use the CENTURY 21 Colonial Post Sign made to Franchise Identification System Specifications unless prohibited from doing so by the client or by law or local ordinance. Yard signs depicted in other formats are offered for your convenience and should only be used when it is not possible to use the Colonial Post Yard Sign.

Please Photocopy
AND ATTACH TO ORDER FORM

60" Sign post system

SPECIAL

ITEM #9000B

COMPLETE SIGN POST KIT WITH PICTURE

Model B

DESCRIPTION:

- A) 6 IMAGE MAKER 60" SIGN POSTS (2 boxes)
complete with ground stakes & pegs
- B) 6 Yard signs (24" x 26") with associated identifier
- C) 12 Message riders (24" x 6")
 - 3 "NEW PRICE"
 - 3 "Open Sunday 2 to 4"
 - 3 "JUST LISTED"
 - 3 "SOLD"

Photo on file* Sending photo by email*

Logos  MULTIPLE LISTING SERVICE

 REALTOR

Company Name: **CENTURY 21**

- A) DBA _____
- B) Agent name: _____
- C) Title: _____
- D) Agent Phone Number: _____
- E) Agent Email: _____
- F) Agent Website: _____

* Note: For quality purpose, agent photos should be taken at the highest possible resolution, but no less than 5.5" x 5.5" at 300 dpi (dots per inch). Color photos can be used.

Please E-mail photo to: HcsSigns@icloud.com



A value of \$ 1045.00
for only **\$ 970.00**

* The CENTURY 21 Policy and Procedures Manual requires that brokers use the CENTURY 21 Colonial Post Sign made to Franchise Identification System Specifications unless prohibited from doing so by the client or by law or local ordinance. Yard signs depicted in other formats are offered for your convenience and should only be used when it is not possible to use the Colonial Post Yard Sign.

Please Photocopy
AND ATTACH TO ORDER FORM

60" Sign post system

ITEM #9000C



A value of \$ 1030.00
for only **\$ 955.00**

SPECIAL

COMPLETE SIGN POST KIT WITH PICTURE Model C

DESCRIPTION:

- A) 6 IMAGE MAKER 60" SIGN POSTS (2 Boxes)
complete with ground stakes & pegs
- B) 6 Yard signs (24" x 26") with associated identifier
- C) 12 Message riders (24" x 6")
 - 3 "NEW PRICE"
 - 3 "Open Sunday 2 to 4"
 - 3 "JUST LISTED"
 - 3 "SOLD"

Photo on file* Sending photo by email*

Logos  

CompanyName: **CENTURY 21**

- A) DBA _____
- B) Agent name: _____
- C) Title: _____
- D) Agent Phone Number: _____
- E) Agent Email: _____
- F) Agent Website: _____

* Note: For quality purpose, agent photos should be taken at the highest possible resolution, but no less than 5.5" x 5.5" at 300 dpi (dots per inch). Color photos can be used.

Please E-mail photo to: HcsSigns@icloud.com

* The CENTURY 21 Policy and Procedures Manual requires that brokers use the CENTURY 21 Colonial Post Sign made to Franchise Identification System Specifications unless prohibited from doing so by the client or by law or local ordinance. Yard signs depicted in other formats are offered for your convenience and should only be used when it is not possible to use the Colonial Post Yard Sign.

Please Photocopy
AND ATTACH TO ORDER FORM

ITEM #6090

Special Features And Activities

DESCRIPTION:

Printed 2 sides on 4 mm coroplast sign riders (white coroplast can be translucent in very bright areas)

FOR SALE

OPEN HOUSE

SOLD

SOLD

Model:

A

B

C

D

24" x 6"

6 = \$ 13.30 each

12 = \$ 12.60 each

24 = \$ 11.90 each

50 = \$ 11.60 each

100 = \$ 11.35 each

24" x 8"

6 = \$ 14.25 each

12 = \$ 13.55 each

24 = \$ 12.85 each

50 = \$ 12.55 each

100 = \$ 12.30 each

36" x 8"

6 = \$ 23.10 each

12 = \$ 21.70 each

24 = \$ 20.30 each

50 = \$ 19.70 each

100 = \$ 19.25 each

Grommets: Top Bottom Center for steel frames None

NOTE: Minimum of 6 signs, no mixing

Sign #'s: _____ Quantity: _____

Ajouts en Français

Description: _____

7 0 0	Commercial	7 1 2	Ouvert →	7 2 3	Visite libre	7 3 8	Visite libre dimanche 14h à 16h	7 5 1	Intérieur à voir!
7 0 1	Bureau	7 1 3	Reprise de finance	7 2 4	À louer	7 4 0	Modèle ouvert →	7 5 2	Prix révisé
7 0 2	3 chambres	7 1 4	→	7 2 7	Lot	7 4 1	Ferme	7 5 3	Visite libre dimanche 13h à 15h
7 0 5	Bord du lac	7 1 5	Visite libre dimanche 13h à 16h	7 2 8	Vente en attente	7 4 2	Ouvert samedi	7 5 4	Visite sam. ____ à ____
7 0 6	Piscine	7 1 6	À vendre	7 2 9	Location	7 4 3	Ouvert dimanche	7 5 6	Droit de passage au lac
7 0 7	Sur rendez-vous seulement	7 1 7	Financé par le propriétaire	7 3 0	Bord de l'eau	7 4 4	Vendu mais nous en avons d'autres	7 5 7	Lot # _____
7 0 8	Vendu	7 1 8	Exclusif	7 3 1	Immeuble à revenus	7 4 5	Grand terrain	7 5 8	Nouveau sur la liste!
7 0 9	2 familles	7 1 9	Lots	7 3 2	Visite libre →	7 4 8	Duplex	7 5 9	En contrat
7 1 0	4 chambres	7 2 0	Prix révisé	7 3 3	À louer	7 4 9	Maison à vendre →	7 6 0	Intergénération
7 1 1	____ Acres	7 2 2	Disponible	7 3 5	Maison adaptée	7 5 0	Maison garantie	7 6 1	Condo

ITEM #6090

Special Features And Activities

DESCRIPTION:

Printed 2 sides on 4 mm coroplast sign riders (white coroplast can be translucent in very bright areas)

FOR SALE

OPEN HOUSE

SOLD

SOLD

Model:

A

B

C

D

24" x 6"

6 = \$ 13.30 each

12 = \$ 12.60 each

24 = \$ 11.90 each

50 = \$ 11.60 each

100 = \$ 11.35 each

24" x 8"

6 = \$ 14.25 each

12 = \$ 13.55 each

24 = \$ 12.85 each

50 = \$ 12.55 each

100 = \$ 12.30 each

36" x 8"

6 = \$ 23.10 each

12 = \$ 21.70 each

24 = \$ 20.30 each

50 = \$ 19.70 each

100 = \$ 19.25 each

Grommets: Top Bottom Center for steel frames None

NOTE: Minimum of 6 signs, no mixing

Sign #'s: _____ Quantity: _____

Ajouts en Français

Description: _____

7
0
0 COMMERCIAL

7
1
2 OPEN →

7
2
3 OPEN HOUSE

7
3
8 OPEN SUNDAY 2-4

7
5
1 MUST SEE INSIDE!

7
0
1 OFFICE

7
1
3 AUCTION

7
2
4 FOR LEASE

7
4
0 MODEL OPEN →

7
5
2 NEW PRICE!

7
0
2 3 BEDROOM

7
1
4 →

7
2
7 LOT

7
4
1 FARM

7
5
3 OPEN SUNDAY 1-3

7
0
5 LAKEFRONT

7
1
5 OPEN SUNDAY 1-4

7
2
8 SALES PENDING

7
4
2 OPEN SATURDAY

7
5
4 OPEN SAT. ___ TO ___

7
0
6 SWIMMING POOL

7
1
6 FOR SALE

7
2
9 RENTALS

7
4
3 OPEN SUNDAY

7
5
6 LAKE RIGHTS

7
0
7 BY APPT. ONLY

7
1
7 OWNER FINANCE

7
3
0 WATERFRONT

7
4
4 SOLD
BUT WE HAVE OTHERS

7
5
7 LOT # _____

7
0
8 SOLD

7
1
8 EXCLUSIVE

7
3
1 INCOME PROPERTY

7
4
5 ACREAGE

7
5
8 NEW LISTING

7
0
9 2 FAMILY

7
1
9 LOTS

7
3
2 OPEN HOUSE →

7
4
8 DUPLEX

7
5
9 IN CONTRACT

7
1
0 4 BEDROOM

7
2
0 PRICE REDUCED

7
3
3 FOR RENT

7
4
9 HOME FOR SALE →

7
6
0 MULTI-FAMILY

7
1
1 _____ ACRES

7
2
2 AVAILABLE

7
3
5 BUILT TO SUIT

7
5
0 HOME WARRANTY

7
6
1 CONDO

EMAIL US YOUR PRINT AND SIZE FOR A PRICE QUOTE

ITEM#6095

CUSTOM VINYL GRAPHIC STICKERS

- Black sticker, white lettering Size of Sticker: _____
- White sticker, black lettering
- Transparent sticker, white or black lettering

Message print: _____

ITEM#7000

WHITE OR BLACK STICKERS WITH BLACK OR WHITE LETTERING

SIZE		QUANTITY			
		15	25	50	100
<input type="checkbox"/>	15" X 3"	\$4.85 each	\$3.65 each	\$3.25 each	\$2.20 each
<input type="checkbox"/>	21" X 3"	\$5.45 each	\$4.15 each	\$3.75 each	\$3.15 each

Message print: _____

ITEM#7005

TRANSPARENT STICKERS WITH WHITE OR BLACK LETTERING

SIZE		QUANTITY			
		15	25	50	100
<input type="checkbox"/>	15" X 4'	\$5.65 each	\$4.15 each	\$3.65 each	\$3.40 each

Message print: _____

ITEM#7010

EXTRA LARGE PERSONALIZED STICKERS

SIZE		QUANTITY	
		15	25
<input type="checkbox"/>	24" X 7.5"	\$10.70 each	\$8.50 each

Message print: _____

Please Photocopy
AND ATTACH TO ORDER FORM

ITEM#7015A

Model A



24" x 18" Open House Signs

DESCRIPTION:

- Printed 1 side only
- 4 mm coroplast sign

White coroplast can be translucent in very bright areas

Minimum order = 12

Specify:

MODEL A

FORSALE → QTY:___ ← QTY:___

OPEN HOUSE → QTY:___ ← QTY:___

12 = \$ 22.70 each

24 = \$ 21.45 each

50 = \$ 20.20 each

Yard Sign Printing Specifications:

A) Company Name: **CENTURY 21**

DBA _____

B) Agent name: _____

C) Agent Phone Number: _____

D) Agent website or Email: _____

ITEM#7070

page 31

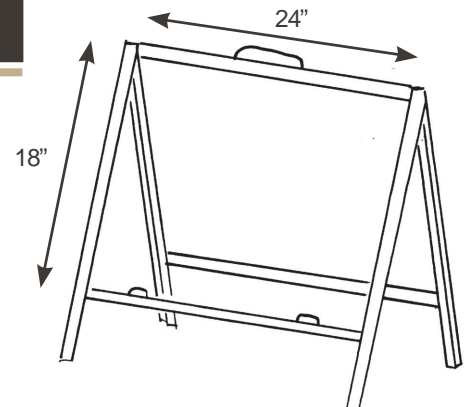

Please Photocopy
AND ATTACH TO ORDER FORM

ITEM#7015B

Model B



24" x 18" Open House Signs

DESCRIPTION:

- Printed 1 side only
 - 4 mm coroplast sign
- White coroplast can be translucent in very bright areas

Minimum order = 12

Specify:

MODEL B

FORSALE → QTY:____ ← QTY:____

OPEN HOUSE → QTY:____ ← QTY:____

12 = \$ 22.70 each

24 = \$ 21.45 each

50 = \$ 20.20 each

Yard Sign Printing Specifications:

- A) Company Name: **CENTURY 21**
DBA _____
- B) Agent name: _____
- C) Agent Phone Number: _____
- D) Agent website or Email: _____

ITEM#7070

page 31

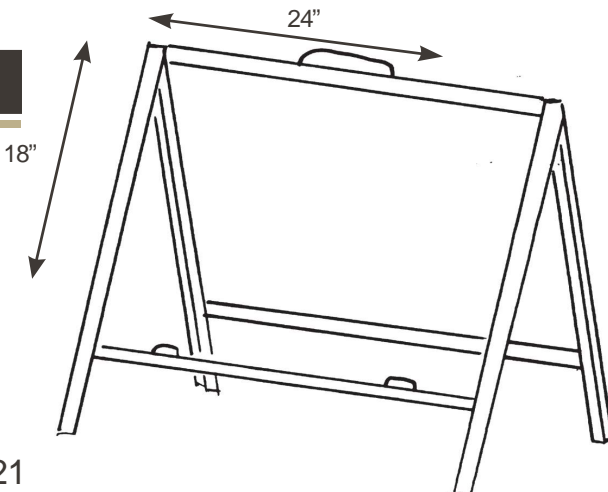

**Please Photocopy
AND ATTACH TO ORDER FORM**

ITEM#7051

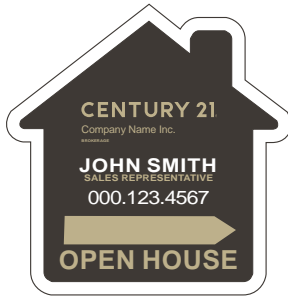
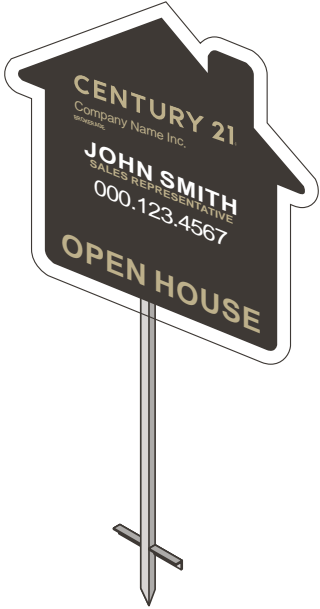

Little House Die-Cut Sign 18" X 18" Directional sign with step stake

DESCRIPTION:

- Printed
- 2 X 4 mm coroplast signs glued back to back
- Includes step stake, nuts and bolts
- Weight: 4.75 pounds each

SIGN PRINTING SPECIFICATIONS:

- A) Company Name: **CENTURY 21**
 DBA _____
 B) Agent name: _____
 C) Title: _____
 D) Agent Phone Number: _____

Specify: OPENHOUSE FOR SALE

- 10 = \$ 62.60 each (2 boxes)
- 15 = \$ 60.10 each (3 boxes)
- 25 = \$ 57.50 each (5 boxes)

ITEM#7052



- 20 = \$ 22.95 each
**Minimum order
 10 per direction**

18" X 18" Single Sided Directional Signs

DESCRIPTION:

- 1 X 4 mm coroplast sign
- Printed 1 side only

SIGN PRINTING SPECIFICATIONS:

- A) Company Name: **CENTURY 21**
 DBA _____
 B) Agent name: _____
 C) Title: _____
 D) Agent Phone Number: _____

Indicate direction of arrow:

Arrow right QTY: _____

Arrow left QTY: _____

Specify: OPENHOUSE FOR SALE

**Please Photocopy
 AND ATTACH TO ORDER FORM**

and Stakes

ITEM#7035



Model A



Model B



- 10 = \$ 53.70 each (2 boxes)
- 15 = \$ 50.80 each (3 boxes)
- 25 = \$ 48.20 each (5 boxes)

24" x 12" - Directional Sign With Step Stake

DESCRIPTION:

- 2 X 4 mm coroplast signs glued back to back
- Includes step stake, nuts and bolts
- Imprinted with DBA and Agent identifier
- Weight: 4.75 lbs each

Choose from two color schemes!

Model A B

Specify: OPENHOUSE FOR SALE
AGENTPHOTO ADDRESS

SIGN PRINTING SPECIFICATIONS:

- A) Company Name: **CENTURY 21**
DBA _____
- B) Agent Name: _____
- C) Title: _____

ITEM#7040

Model A



Model B



- 20 = \$ 18.30 each
- 30 = \$ 17.05 each
- 50 = \$ 15.75 each

24" x 12" - Single Sided Directional Sign

DESCRIPTION:

- 1 X 4 mm coroplast sign
- Printed one side only
- Imprinted with DBA and Agent identifier

Choose from two color schemes!

Model A B

Specify: OPENHOUSE FOR SALE

Indicate direction of arrow:

Arrow Right QTY: _____

Arrow Left QTY: _____

- A) Company Name: **CENTURY 21**
DBA _____
- B) Agent Name: _____
- C) Title: _____

Please Photocopy
AND ATTACH TO ORDER FORM

ITEM#7025



Model A



Model B



Model C



Model D



24" x 8"

Directional Sign With Step Stake

DESCRIPTION:

- 2 X 4 mm coroplast signs glued back to back
- Printed 1 side only
- Includes step stake, nuts and bolts
- Weight: 3.75 lbs each

SPECIFICATION:

MODEL A B D D

FOR SALE • QTY: _____ OPEN HOUSE • QTY: _____

10 = \$ 44.20 / ea. (2 boxes)

15 = \$ 41.40 / ea. (3 boxes)

25 = \$ 39.60 / ea. (5 boxes)

Company Name: **CENTURY 21**

A) DBA _____

ITEM#7030

Model A



Model B



Model C



Model D



24" x 8"

Directional Sign

DESCRIPTION:

- 4 mm coroplast
- Printed 1 side only

SPECIFICATION: MINIMUM 10 EACH DIRECTION, NO MIXING

MODEL A B C D

Printed 2 sides

10 = \$ 15.30 / ea.

15 = \$ 13.95 / ea.

25 = \$ 13.25 / ea.

Printed 1 side

20 = \$12.60 / ea.

30 = \$11.95 / ea.

50 = \$11.45 / ea.

FOR SALE → QTY: _____ ← QTY: _____

OPEN HOUSE → QTY: _____ ← QTY: _____

Company Name: **CENTURY 21**

A) DBA _____

Please Photocopy
AND ATTACH TO ORDER FORM

ITEM#7055

Model A



Model B

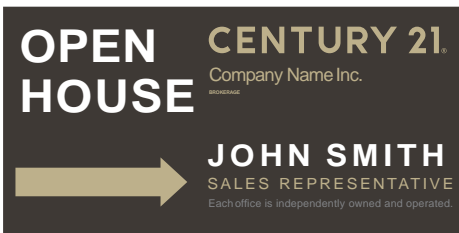

Model C

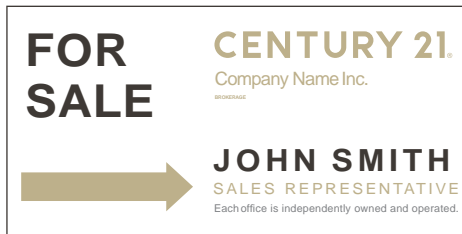

Model D

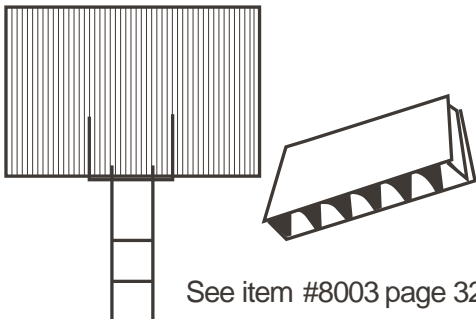
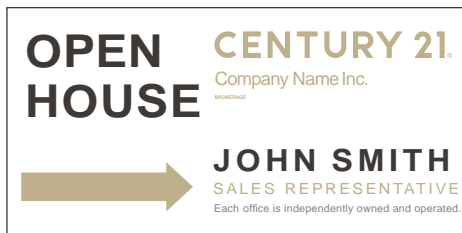

See item #8003 page 32

24" X 12" Directional sign with wire stakes

DESCRIPTION:

- Printed 2 sides
- With 30" galvanized wire stakes
- Use these lightweight, moisture proof, 4 mm corrugated plastic signs where cost is a factor. They will fit our H-Frame Wire Stake (sold separately. Signs are available with vertical flutes only and are printed on both sides. Personalized at no extra charge
- Weight: 4.75 pounds each

YARD SIGN PRINTING SPECIFICATIONS:

- A) Company Name: **CENTURY 21**
- B) DBA: _____
- C) Title: _____
- D) Agent name: _____
- E) Agent Phone Number: _____

Specify: **OPENHOUSE** or **FORSALE**

Model **A** **B** **C** **D**

- 12 Directional signs & stakes= \$ 25.55 each (1 box)
- 24 Directional signs & stakes= \$ 24.15 each (2 boxes)
- 48 Directional signs & stakes= \$ 22.75 each (4 boxes)

Galvanized Wire Stake

- 10" X 30" galvanised stake
- 1/8" Wire construction
- For use with 4mm Corrugated sign panels
- Affordable and easy to use

Please Photocopy
AND ATTACH TO ORDER FORM

ITEM#7060 Step Stake Nuts And Bolts

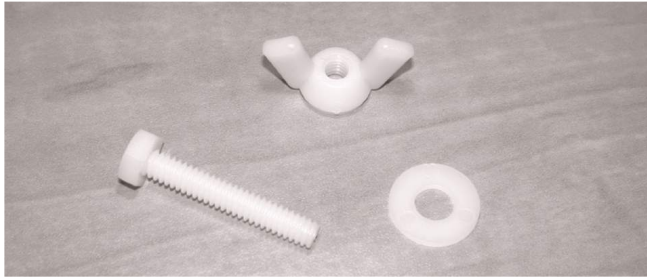

1 Bag =
10 bolts
10 wing nuts
20 washers

PRICE: \$ 4.70 each bag

ITEM#7065 Sign Pegs

DESCRIPTION:

- Plastic Sign Holder Pegs
- Packages of 9

- Model A (White)**
- Model B (Gold)**
- Model C (Black)**

PRICE: \$ 25.75 per bag

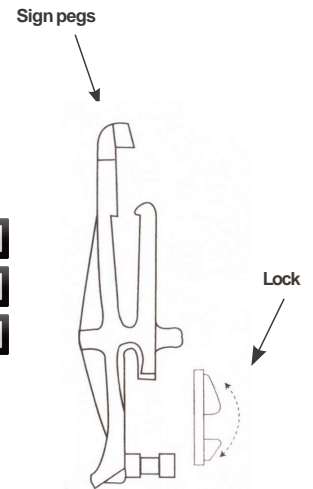

ITEM#7070 A-Frame or Tent Frame

DESCRIPTION: Powder coated For OPENHOUSE, FOR SALE and DIRECTIONAL

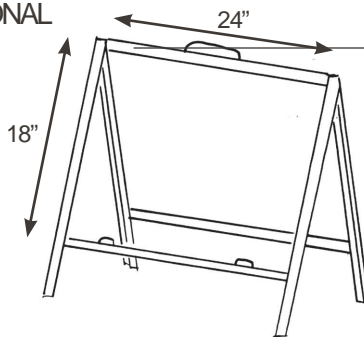

PRICE: Available only in boxes of 4: **\$ 44.90 each frame**

ITEM#7075 Rider Sign Hanger Clips

DESCRIPTION:

- 100% Stainless Steel Clips, For Hanging Name Rider Signs
- 36 clips per bag

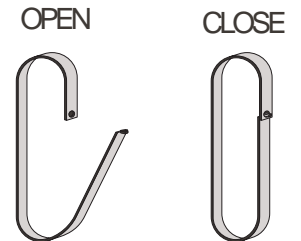

PRICE: \$ 29.30 per bag

ITEM#7080 Residential Steel Yard Frame

NO INSTALLER NECESSARY
QUICK AND EASY TO INSTALL

- Accommodates our 24" x 18" 4 mm Coroplast sign (Item #6005) and has special feature for holding Sign riders 24" x 6"
- Black powder coat
- 3/4" Steel angle frame

QTY	4-20	24-100
PRICE	\$ 57.20	\$ 53.90
	each frame	each frame

NEW DESIGN

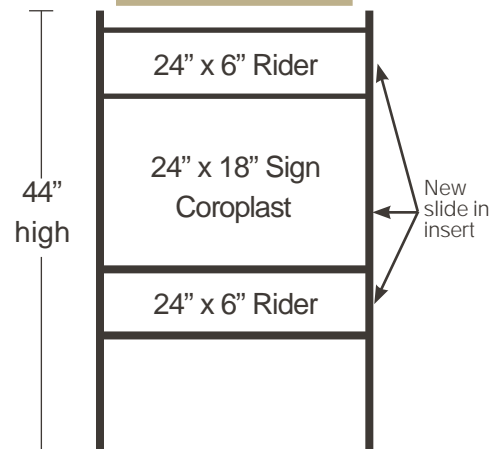

Please Photocopy AND ATTACH TO ORDER FORM